



**Johnson
Screens**

A brand of
Aqseptence Group

120° Pressure Box

Johnson Screens' 120° Pressure Fed Boxes are used for fine solids separation. Slurry is evenly distributed through the patent pending movable nozzles and evenly pressure fed onto Vee-Wire® screens. Liquid then drains through the Vee-Wire screen slots as the solids slide to the bottom of the screen for further processing.

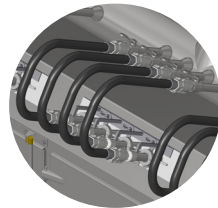

**Movable
Nozzles**

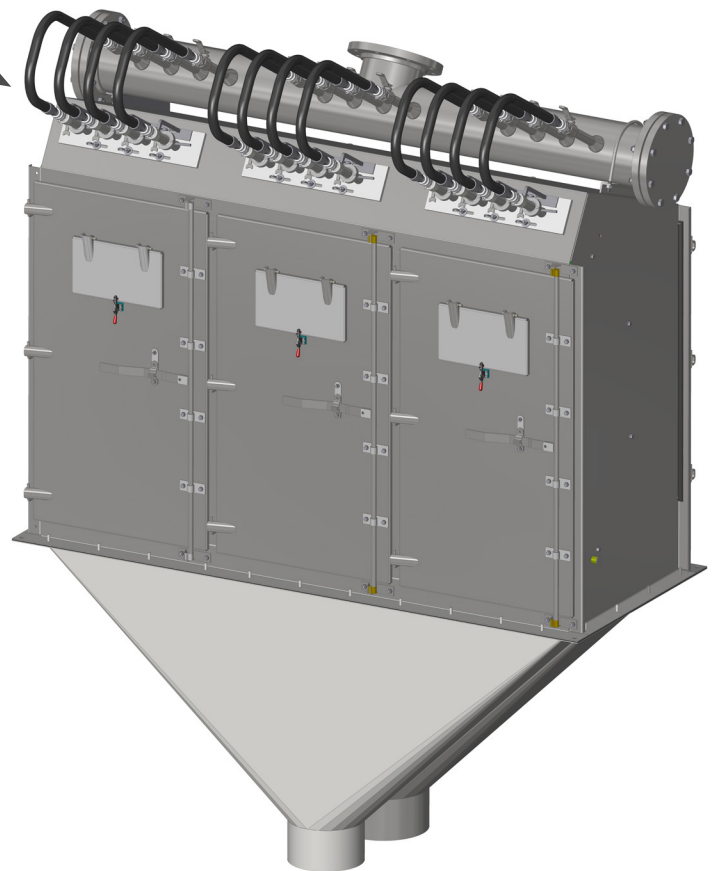

Features and Benefits

- Constructed from 316L stainless steel (other options available upon request)
- Available in single, double and triple screen units
- Sight doors to monitor flow conditions
- Process flow designed for even distribution through nozzles that can increase screen life by up to 30%
- External nozzle adjustment limits SO₂ exposure
- Flexible nozzle hoses for easier nozzle adjustment
- Food grade seals and door clamps greatly reduces leakage
- Oversized doors allow for easier screen cleaning
- Two step screen removal system, limits SO₂ exposure and reduces maintenance time by changing screen outside of the box
- 316L, 304 and Duplex Vee-Wire screens available in .015, .020 and .030 in. slot size

Johnson Screens
Industrial and Architectural Screens

North and South America
Phone +1 651 636 3900
info.us@johnsonscreens.com

Europe, Middle East & Africa
Phone +3 3 23 75 05 42
info.fr@johnsonscreens.com

Asia Pacific
Phone +61 7 3867 5555
info.au@johnsonscreens.com

johnsonscreens.com