



Johnson Screens

A brand of
Aqseptence Group

Mineral Processing



A brand of
Aqseptence Group

Sieve Bends

Johnson Screens' sieve bend screens are used in static sieves for either dewatering or classification.

The dewatering capability of a screen is determined by the percentage of open area. Johnson's screens have the capability to provide up to 50% more open area, because of our greater range of narrower wire profiles. The wires can be as narrow as 0.5 mm (0.020 in.) and up in 0.25 mm (0.010 in.) increments.

With increasing mine site safety awareness Johnson Screens, has developed an innovative split sieve concept. This offers easier handling of the larger width sieve bends, particularly those 1500 mm (59.06 in) and over. This is a major benefit because of the reduced size and weight of the screens

Vibratory sieve bend assembly

Used for dewatering and sizing fine slurry feed. Vibration is evenly distributed to the screen surface by Johnson Screens patented dual vibratory motor/shaft combination thus effectively achieving higher flow rates and sizing down to 200 microns.

Wire - Static sieve bend assemblies

Used widely in the food, sugar, pulp, paper and waste water industries, there are no moving parts. The screens are self-cleaning with very low maintenance requirements.

Reversible sieve bend assembly

This type of sieve bend assembly includes the option of a pneumatic cylinder for raising and lowering of the cradle. To maintain optimum screen performance, the screen can be rotated 180 degrees. The size of wire used to

Static sieve bend dewatering capacity

(gpm per ft. of screen width, m³ per hr per meter of screen width)

Slot Opening	30 in. Arc length (76.2 cm)			40 in. Arc length (101.6 cm)			48 in. Arc length (121.9 cm)			60 in. Arc length (152.4 cm)			80 in. Arc length (203.2 cm)		
	Vee-Wire number			Vee-Wire number			Vee-Wire number			Vee-Wire number			Vee-Wire number		
	63	93	118	63	93	118	63	93	118	63	93	118	63	93	118
.100 in	325	280	245	375	320	280	405	350	305	440	375	330	455	395	345
2.50 mm	242	209	182	279	238	207	302	261	228	328	279	246	339	294	257
.080 in	290	250	220	335	290	255	365	315	275	390	340	300	405	350	310
2.00 mm	216	186	164	250	216	190	272	235	205	290	253	224	302	261	231
.060 in	260	220	190	300	255	220	325	275	240	350	300	255	365	305	265
1.50 mm	194	164	142	224	190	164	242	205	179	261	224	224	272	227	197
.050 in	240	205	170	275	235	195	300	255	220	325	275	230	335	285	240
1.25 mm	179	153	127	205	175	145	224	190	164	242	205	171	250	212	179
.040 in	220	185	150	255	215	175	275	230	190	300	250	200	305	265	210
1.00 mm	164	141	112	190	160	130	205	172	142	224	186	149	227	197	156
.035 in	195	165	130	225	190	150	245	220	165	265	225	170	275	230	180
.87 mm	145	123	97	168	142	112	183	169	123	197	168	127	205	171	134
.030 in	165	145	120	190	170	140	205	180	150	225	200	160	230	205	170
.75 mm	123	108	89	142	127	104	153	134	112	168	149	119	171	153	127
.020 in	130	110	90	150	125	105	165	140	115	175	150	120	180	155	130
.55 mm	97	82	67	112	93	78	123	127	86	130	112	89	134	115	97

Note: capacities shown are based on 20% dry solids by weight, 50 lb/ft³ (803.6 kg/m³) 60 degree slope. Due to allowance must be made for other factors contributing to actual results.

Fine-slot static sieve bend dewatering capacity

(gpm per ft. of screen width, m³ per hr per meter of screen width)

Slot Opening	40 in. Arc length (101.6 cm)				60 in. Arc length (152.4 cm)		
	Vee-Wire number				Vee-Wire number		
	20	30	47	63	30	44	63
.012 in	*	110	80	65	135	100	80
.30 mm	*	82	60	49	102	74	60
.007 in	*	90	65	50	110	80	60
.18 mm	*	67	48	37	82	60	45
.006 in	*	70	50	40	90	60	50
.15 mm	*	52	37	30	67	45	37
.005 in	*	55	40	30	70	50	40
.13 mm	*	41	30	22	52	37	30

Note: capacities shown are based on 23 * 0 mesh size fine coal slurry.

* Data currently not available



Static Sieves: Separation size vs. slot opening and slope of screen

Separation size			Screen opening size					
Tyler mesh	in.	mm	60° slope		45° Slope		30° Slope	
			in.	mm	in.	mm	in.	mm
14	0.045	1.20	0.100	2.50	0.070	1.80	0.055	1.35
16	0.040	1.00	0.080	2.00	0.055	1.35	0.045	1.15
20	0.035	0.88	0.060	1.50	0.045	1.15	0.038	1.00
-	0.030	0.75	0.050	1.25	0.040	1.00	0.033	0.87
26	0.025	0.60	0.040	1.00	0.035	0.87	0.028	0.75
32	0.020	0.50	0.035	0.87	0.030	0.75	0.024	0.65
35	0.016	0.40	0.030	0.75	0.025	0.65	0.020	0.50
48	0.012	0.30	0.020	0.50	0.017	0.45	0.015	0.40
65	0.008	0.20	0.014	0.35				
80	0.007	0.18	0.012	0.30				
100	0.006	0.15	0.010	0.25				

Centrifuge Baskets

Johnson Screens' centrifuge screen baskets are the strongest and most robust in the mineral processing industry today. Built to exacting specifications and quality standards that are known throughout the industry, Johnson Screens centrifugal baskets are designed to work with most dryers.

Johnson Screen offers a variety of wire shapes and configurations which allow our engineers to design the most efficient centrifuge basket for specific application.

Johnson Screens wire shapes are designed to maximize wear life and open area and all baskets are engineered to better maintain constant slot integrity during the life of the basket. Screen wires are welded to support rods at every junction to ensure strong, rigid construction.

Each basket is balanced before shipping to ensure long lasting service. Specialty coatings and Vee Wire materials are available.



Polyurethane Screening Systems

Mineral processors throughout the world have cost-per-ton reductions by using Johnson Screens polyurethane screening systems in classifying, reducing, sizing, washing or dewatering processes.

Johnson Screens offers comprehensive range of polyurethane screening systems that will provide value every day in the processing of coal, iron ore, gold, phosphate, copper, lead and zinc, bauxite, sand and gravel and many other minerals.

Johnson Screens' polyurethane panels have the ability to incorporate other surface media with the lateral

engaging clip design. For example: Vee-Wire, perforated plate, rubber panels or high impact panels incorporating ceramic tiles.

The ability to combine differing materials and modules allows for plant manager to manage the screen as desired. This "configured deck" concept is another way that Johnson Screens can help get the most out of a operation.

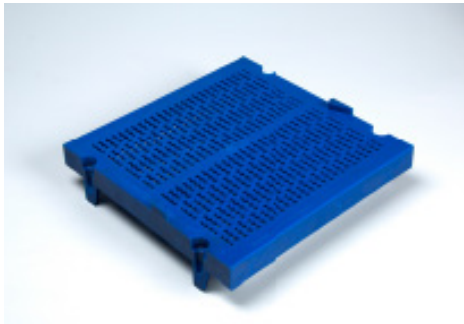

Vibratory Panels

Fully welded Johnson Screens' Vee-Wire vibratory panels are used for dewatering, sizing, media recovery, and classification.

Johnson Screens flat panels are resistance-welded at every wire and support rod juncture to allow them to be self-supported. Alternatively, crowned flat panels have the profile wire resistance welded to round, stainless steel support rods is supported by bumper bar. These screens are typically used in vibratory mineral applications. They are dependable, strong and effective.

The slot tolerance for the Vee-Wire screen is $\pm 25 \mu\text{m}$ depending on the size of the wire. Wire sizes vary in size from 0.05 mm / 50 μm to 12.7 mm / 0.5 in. Wire size and slot size will be determined by the application of the screen. Our engineers will be able to assist you in your design selections of specialty coatings and wear material.

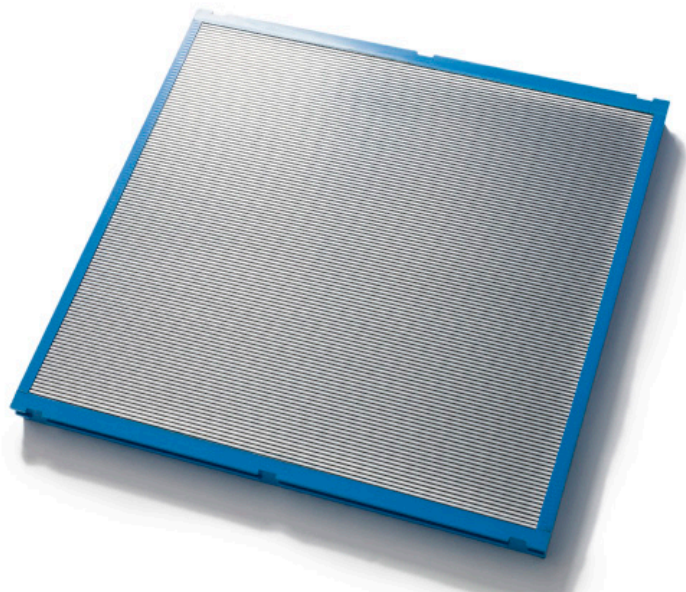

Polyurethane Screening Systems

The use of polyurethane tensionable mats as a screening surface has significant advantages when the application is appraised correctly:

- Polyurethane tension mats have a long life when screening materials such as quartz, silicon sand, and gravel
- Polyurethane exhibits the characteristic elasticity of rubber
- The distinct advantage polyurethane mats have over rubber is the accuracy of the cast apertures
- Polyurethane tension mats, when compared to the punched apertures in rubber, allow for more precise screening

Johnson Screens' design allows for the correct relief angle to be designed into each application, ensuring optimum performance

As a result 'pegging' and 'binding' is minimized, reducing the frequency of scheduled stoppages caused by screening surface failure.



Modular Screen Panels

Johnson Screens' fine aperture modular screen panels has one of the highest open areas on the market



Open area, or ratio of apertures to total panel surface area, is of crucial importance to screen users at a time when plants are upgrading their capacity to increase throughput and profitability.

Open area for the continuous slot pattern is about 40-50% greater than standard polyurethane modular panels of the same aperture, which means greater throughput through the same screen or alternatively, better screening results for the same feed.

Field-tested over an extended period in a number of coal screens, continuous slot can be used in any fine aperture screening application. Continuous slot is compatible with horizontal or banana type screen decks.

Continuous slot is ideally suited for all dewatering, de-sliming and fine classification and drain / rinse – (heavy media) recovery applications.

Vee-Wire Screening Technologies



Johnson Screens offer a wide variety of Vee-Wire screens (often known as wedge wire or profile wire screens) for particle separation, dewatering, classifying, and related mineral processing applications.

Each intersection of surface wire and internal support rods is welded, producing a very strong screen.

Johnson Screens flat screens can be fabricated with very small wires and rods for critical fine screening operations or with much larger wires and rods for heavy-duty operations.

Welded wire screens use a surface wire that is V-shaped in profile, creating slots that enlarge inwardly.

This means particles make only two-point contact in the slots reduces the opportunity for pegging.

Vee-Wire Flat Panels

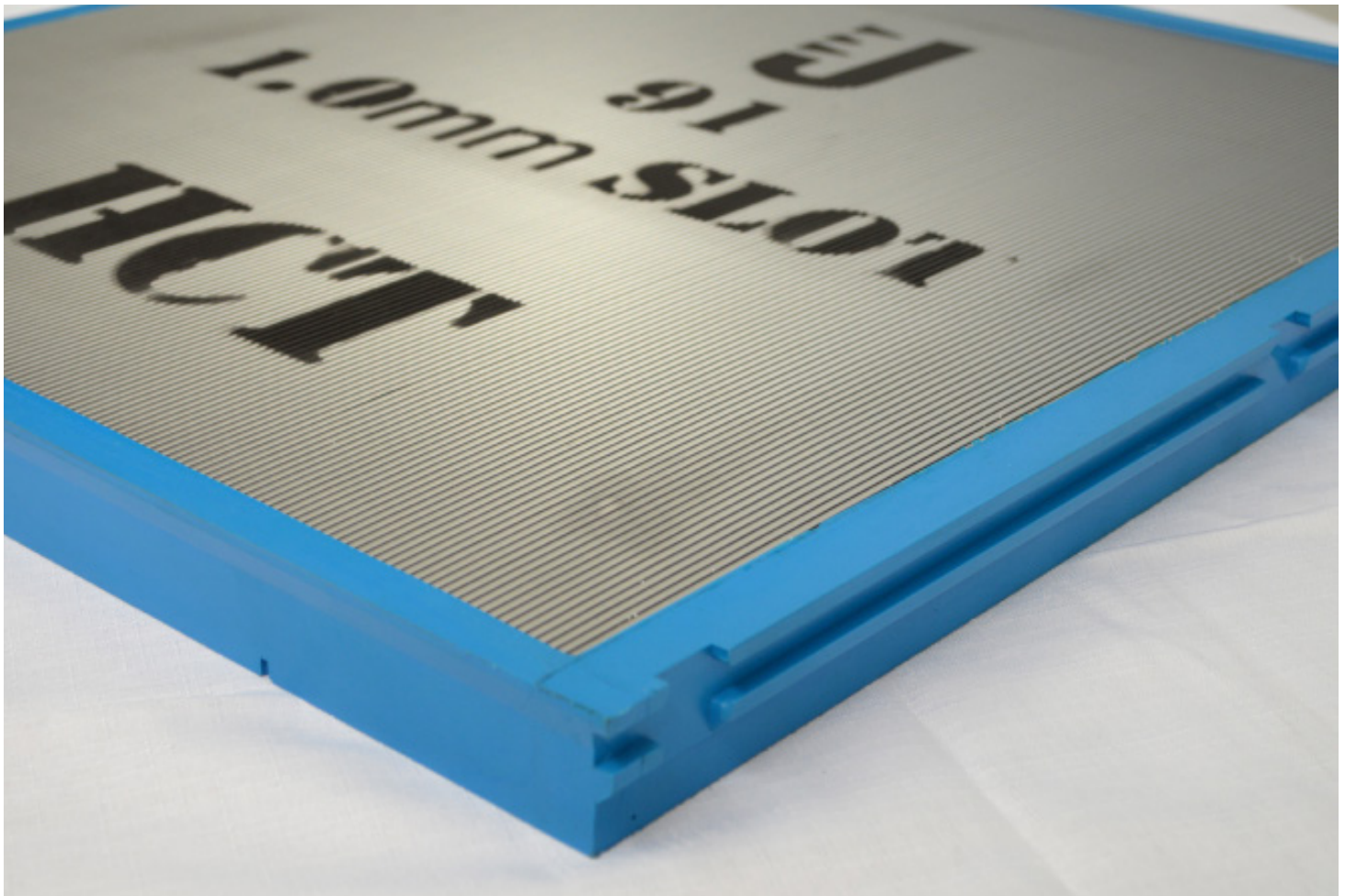

Fully welded Johnson Screens Vee-Wire flat screens are used for dewatering, sizing and media recovery and classification. Rigid flat panels are resistance welded at each wire and support rod juncture.

These screens are typically used by the coal and iron ore mining industry in mineral processing vibrating screens.

The slot tolerance for the Vee-Wire screen is $\pm .025$ mm (.001 in) depending on the size of the wire. Wire sizes vary from 0.5 mm (0.020 in.) to 12.7 mm (0.5 in) in size. Wire size and slot size are determined by the application of the screen. Our engineers are able to assist you in your selections of both.

Johnson Screens can provide any number of individually designed flat panels to suit static screening applications.

Our engineers will assess your application and provide you with a functional framed design that can be easily mounted in your equipment.

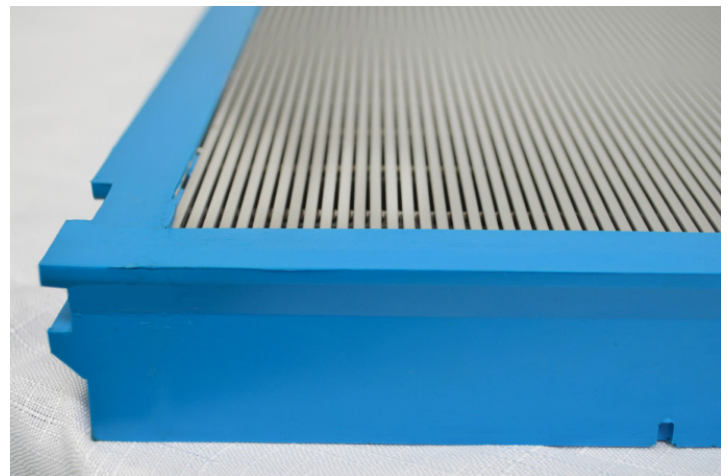

Trommel Screen

Johnson Screens specializes in custom designed cylindrical trommel screen systems

Plant managers understand the advantages of using the Johnson Screens modular screening system for their trommel screens.

- Custom designed for individual applications
- Johnson Screens engineers will assist in determining the appropriate screening media: polyurethane, rubber, woven wire or Vee-Wire media
- All of the virtues of our other polyurethane screening systems are incorporated in our special Trommel screen mats and modules
- Panels can be reinforced as required
- Lightweight screen modules are manufactured with innovative fixing mounts that protect the Trommel and facilitate quick installation
- Suits wet or dry applications
- Successfully screens mineral sands, sand, coal, phosphate and gravel
- Aperture opening sizes and designs can be varied depending upon the application
- Panels can be custom designed and sized as required
- Polyurethane portholes protect the trommel frame
- Vee-Wire Trommels and cylinder screens feature high open area and accurate classification
- Johnson Screens' full ranges of Vee-Wire shapes are available for most designs

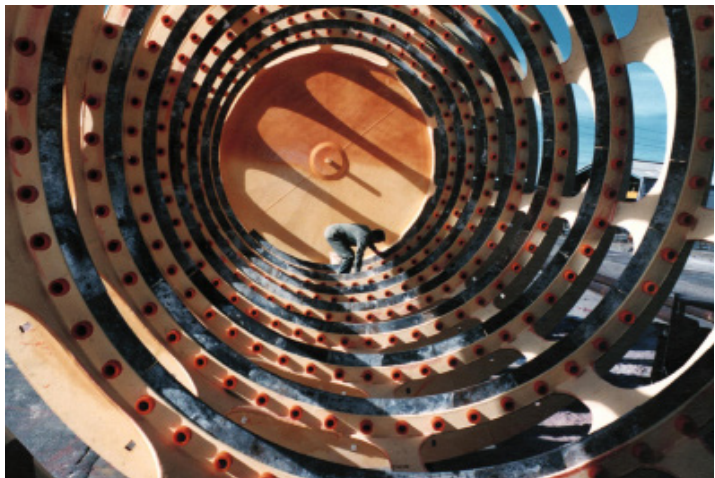

Intertank Screen Assemblies

In the gold and silver mining market, stainless steel Vee-Wire intertank screens are used to recover gold and silver in the slurry separation process.

Johnson Screens' Vee-Wire intertank screens are made from 304 or 316 stainless steel and are designed to withstand the most demanding conditions.

All screens are designed to each customer specification for open area, flow and loads.

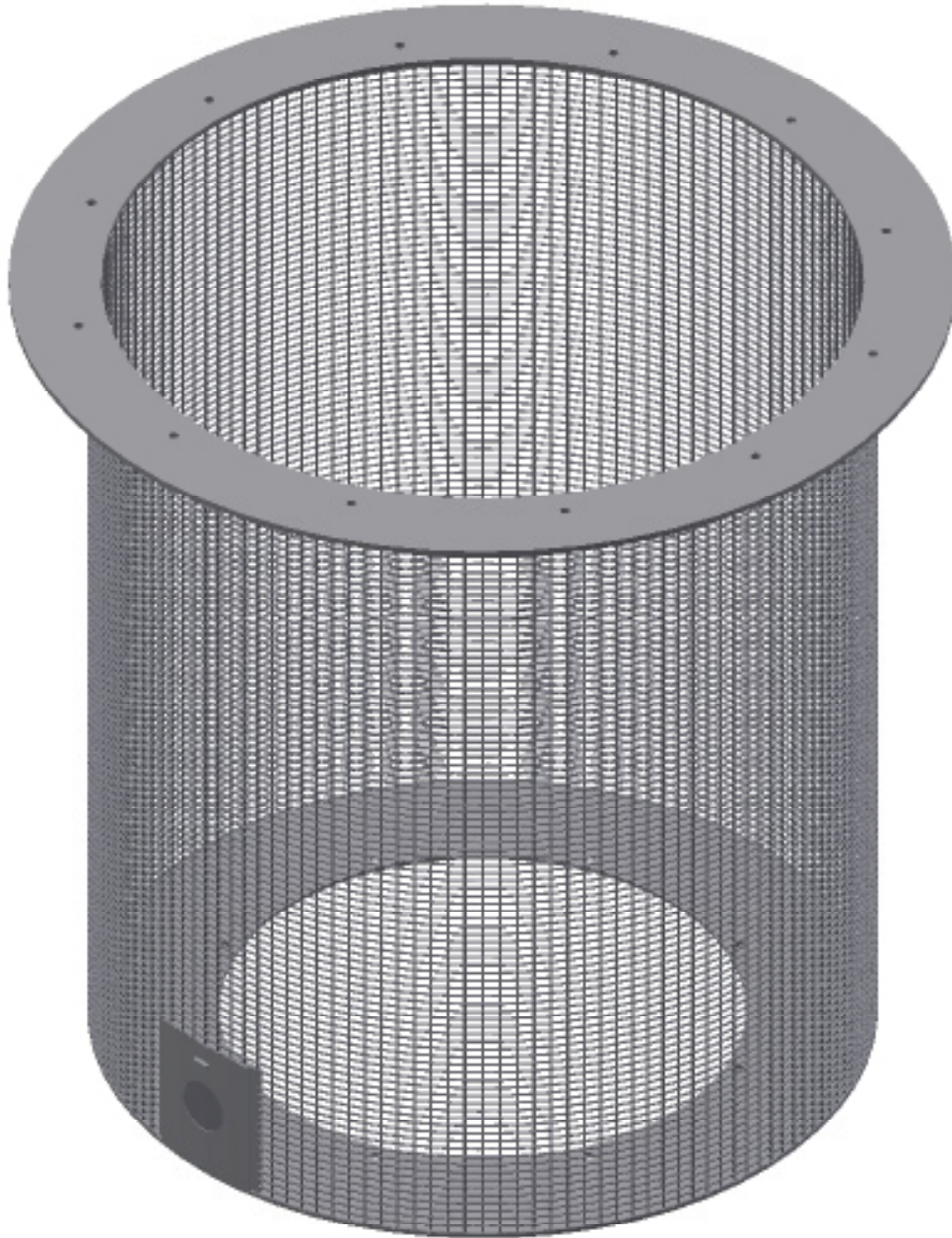

Exceptional Products, Exceptional Service



Field Service

Johnson Screens offers a complete field service team of specialized and experienced members that are available for various projects including:

- Full installation
- On-site repairs
- Technical assistance or expertise
- Work supervision
- Inspection

Flexibility and expertise allow us to propose this extended scope of services under tailor-made contract conditions in order to better serve our clients' requirements.

Our experienced welder/fabricators team is available for on site installation, repairs and screen replacement, and can be available within 24 hours for emergency situations or scheduled as needed.

The ability to evaluate the condition of screens and make recommendations as to the best course of action, our field service team will be there to allow the screens to operate at maximum capacity.

Whether cleaning, making minor or major repairs, or completely replacing screens, our technicians are equipped with all the tools, equipment and experience needed to provide the best field service available.

Our experienced technicians are also available for supervision of installations and on-site repairs.

Looped Wire Assembly and Framing Options

Comprehensive fabrication capabilities allow Johnson Screens to supply a wide range of customized framing and assembly options designed to meet individual customer needs.

Johnson Screens' technical department and engineering staff are available to help create the total profile wire system which is best suited to solve your specific application requirements.

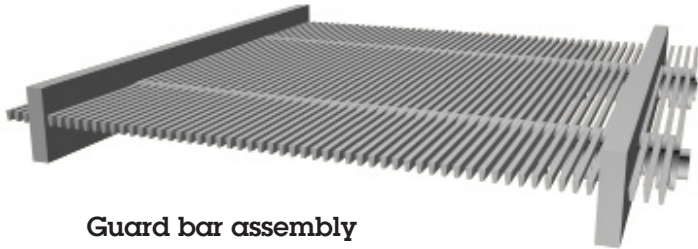

Guard bar assembly

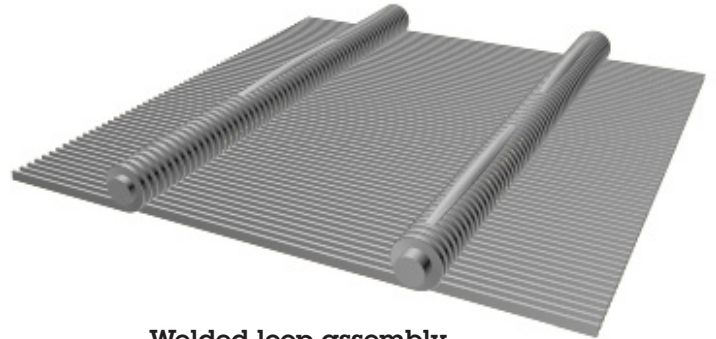

Welded loop assembly

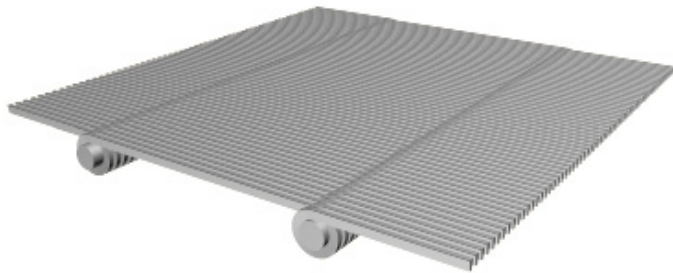

Mat section with no bushing

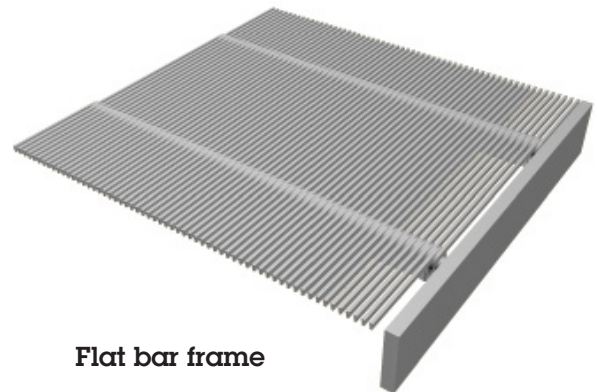

Flat bar frame

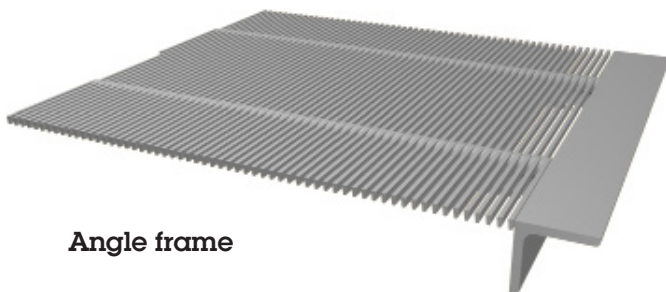

Angle frame

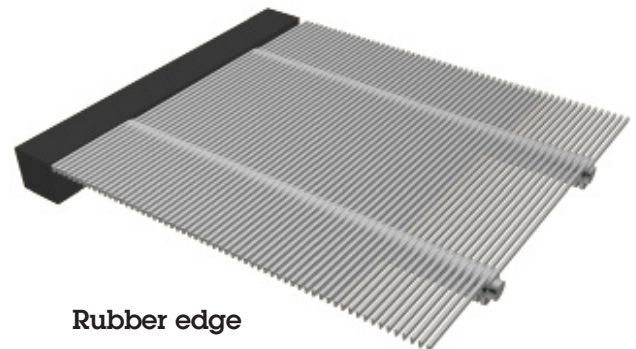

Rubber edge

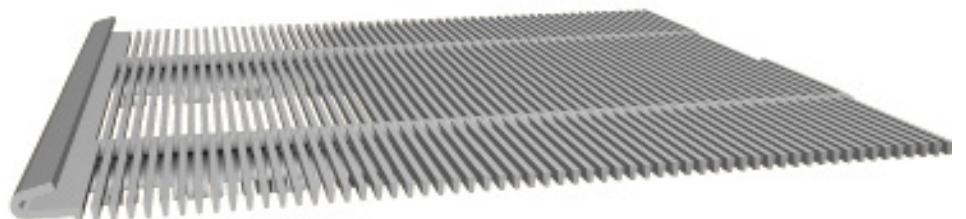

Hook Strip

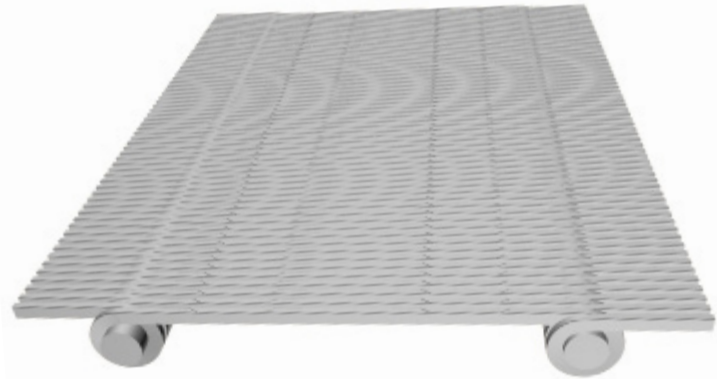

Diamond Top

The "diamond" configuration of this profile wire surface acts to guide liquids toward openings and substantially increases screening efficiency. This action also agitates particles which helps in the prevention of material adhesion.



Blips

In severe screening applications, spacing blips can be placed in the profile wire between standard cross support rod loops. The spacing blips insure accurate and uniform slot openings during operation.

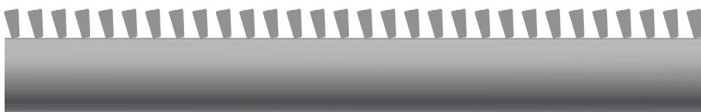

Tilt

The "tilting" of the profile wire angle, typically 5° to 10°, enhances the dewatering and separation of material on cross flow screening applications

Free-Flow

Free-Flow screens are made with a ribbon lock-bar process. This process incorporates cross-bars which are inserted into slotted longitudinal profile bars, rotated 90° and locked into place. The cross bars are then automatically welded on the underside only.

Free-Flow screens are typically used in high wear applications requiring a clear, free slotted screen surface. Free-Flow is available in openings of .010" and larger with total stainless steel construction.

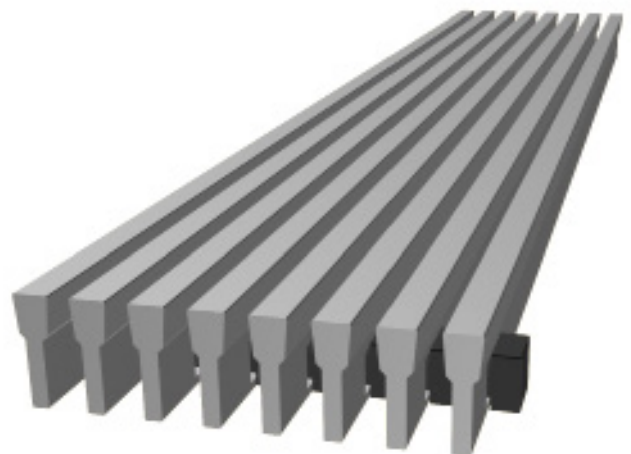

Wire and Rod Information

Vee-Wire® Profiles - Most Commonly Used

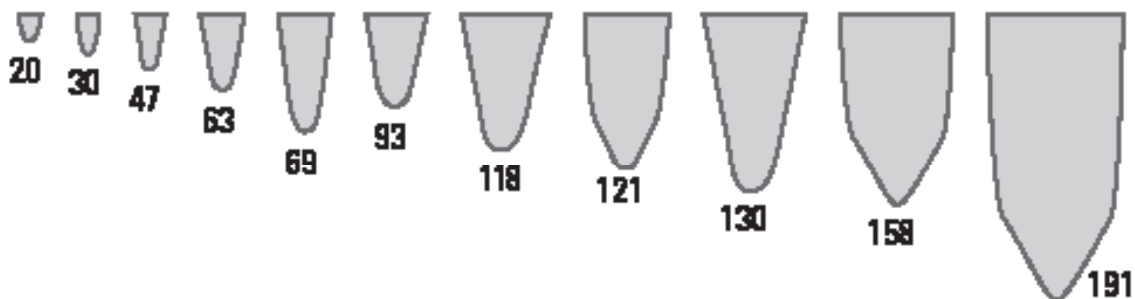

Open Area (%) =

$$\frac{\text{Slot Size} \times 100}{\text{Slot Size} + \text{Wire Width}}$$

Name	Width		Height		Section Area		Relief Angle
	in.	mm	in.	mm	in ²	mm ²	
20	0.020	0.508	0.040	1.016	0.0005	0.323	11°
30	0.030	0.762	0.050	1.270	0.001	0.645	13°
47	0.047	1.194	0.088	2.235	0.003	1.935	10°
63	0.060	1.524	0.100	2.540	0.004	2.581	13°
69	0.071	1.803	0.177	4.496	0.010	6.452	7°
93	0.089	2.261	0.138	3.505	0.009	5.806	13°
118	0.116	2.946	0.185	4.699	0.015	9.677	13°
130	0.130	3.302	0.250	6.350	0.023	14.839	8°
191	0.195	4.953	0.363	9.220	0.055	35.484	5°

Shaped Support Rods

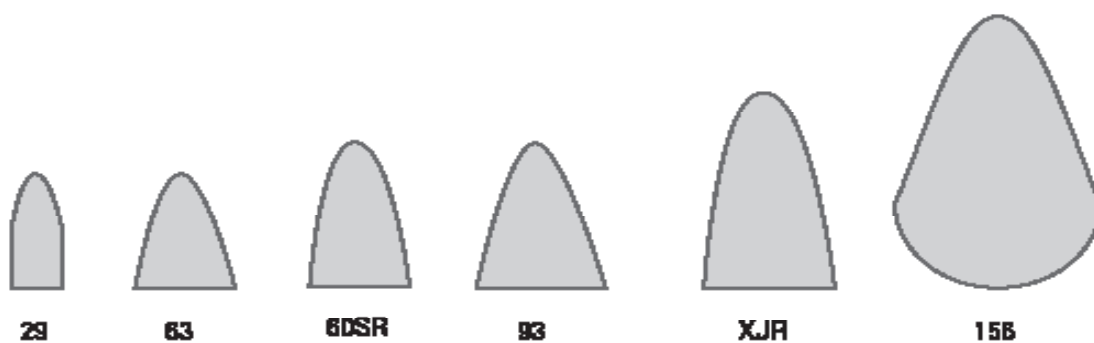

Name	Width		Height		Section Area		Section Modulus (in. ³ x 10 ⁻³)
	in.	mm	in.	mm	in.	mm	
29	0.029	0.737	0.102	2.591	0.003	0.076	0.037
63	0.060	1.524	0.100	2.540	0.004	2.581	0.050
93	0.089	2.261	0.138	3.505	0.009	5.806	0.150
XJR	0.089	2.261	0.189	4.801	0.013	0.330	0.298
60SR	0.060	1.524	0.120	3.048	0.006	0.152	0.077
156	0.151	3.835	0.217	5.512	0.022	0.559	0.600

Examples of Screen Open Area

Wire No.	Percent of Open Area					
	20	30	40	50	60	70
30	0.008	0.013	0.020	0.030	0.045	0.070
47	0.012	0.020	0.031	0.047	0.071	0.110
63	0.015	0.026	0.041	0.060	0.090	0.140
69	0.018	0.030	0.047	0.071	0.107	0.166
93	0.022	0.038	0.059	0.089	0.134	0.208
118	0.029	0.050	0.077	0.116	0.174	0.271
130	0.033	0.056	0.087	0.130	0.195	0.303
158	0.040	0.068	0.105	0.158	0.237	0.369
191	0.049	0.084	0.130	0.195	0.293	0.455
250 TRI	0.063	0.107	0.167	0.250	0.375	0.583
500 TRI	0.125	0.214	0.333	0.500	0.750	1.167

Slot Opening Size (in.)

Standard Welded Construction

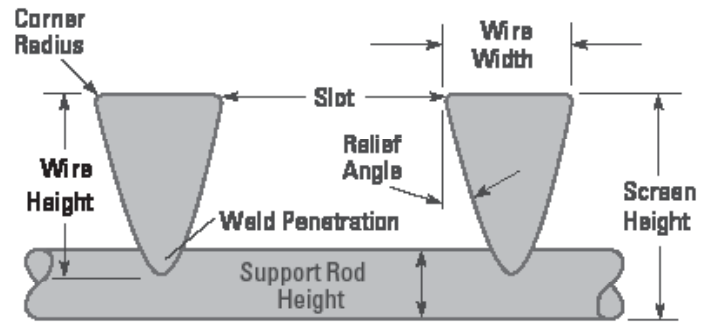

Tri-Wire Profiles

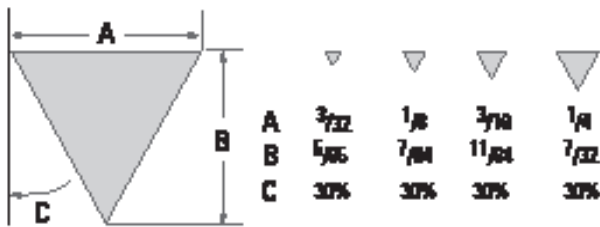

Iso-Grizzly Wire Profile

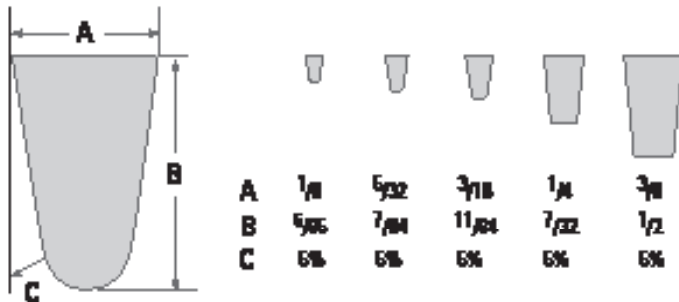
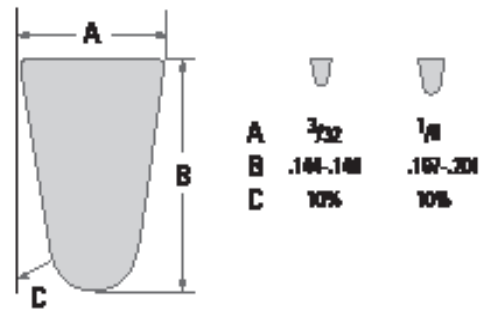

A = Width
 B = Height
 C = Relief Angle

Round and Strip Rods

- Round rods are available in diameters ranging from 0.125 to 0.500 in. (3.175 to 12.7 mm).
- Strip rods are available in widths ranging from 0.070 to 0.188 in. (1.778 to 4.775 mm) and heights ranging from 0.375 to 2.0 in. (9.525 to 50.8 mm).

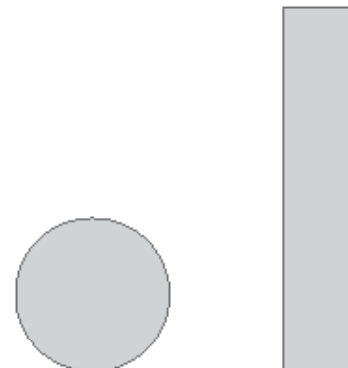

Johnson Screens
Industrial and Architectural Screens

North America
Phone +1 651 636 3900
info.us@johnsonscreens.com

Australia - Asia Pacific
Phone +61 7 3867 5555
info.au@johnsonscreens.com

Europe
Phone +33 5 49021600
info.fr@johnsonscreens.com

India
Phone +91 2717 618000
info.in@johnsonscreens.com

Japan
Phone +81 45 661 3575
info.jp@johnsonscreens.com

Brazil
Phone +55 11 4341-5777
info.johnsonscreens.br@aqseptence.com

Chile
Phone +56 02 9280700
info.johnsoncreens.cl@johnsoncreens.cl

johnsonscreens.com