



**Johnson
Screens**



Passive Intake Screens



A brand of
Aqseptence Group

The world's most efficient passive intake screen system

Johnson Screens' passive intake screen system provides uninterrupted water withdrawal from lakes, rivers and oceans. Johnson Screens' passive intake screen operates continuously and requires no downtime for cleaning or routine maintenance. Moreover, the system can be configured to meet US Environmental Protection Agency (USEPA) regulations for protecting aquatic life.

To provide maximum efficiency, Johnson Screens' passive intake screen is custom designed and engineered to each unique environment, resulting in a system which costs less to install, operate and requires less maintenance.

Maximum Efficiency

The combination of the non-plugging Vee-Wire® design and the patented internal flow modifier, provides a high open area while maintaining the lowest entrance velocity and pressure drop. This delivers a maximum water capacity with minimal entrainment and impingement.

Custom Designed and Engineered

With over 30 years of intake screen experience and thousands of installations covering a variety of conditions, application engineers from Johnson Screens can provide design and application assistance. From shallow rivers to deep oceans, the Johnson Screens passive intake screen systems can meet site requirements anywhere in the world.

Less Maintenance

Johnson Screens' passive intake screen system has no moving parts that can break down or wear out. This eliminates the need to replace worn parts or make other costly repairs. The controlled entrance velocity on the passive intake screen, along with the specially matched Hydroburst™ air backwash, keeps the system clean and operating properly.

Lower Cost

The unique and flexible design of the passive intake screen system results in lower initial costs, no moving parts, less maintenance needs and a simplified installation — allowing for a reliable, inexpensive water supply.

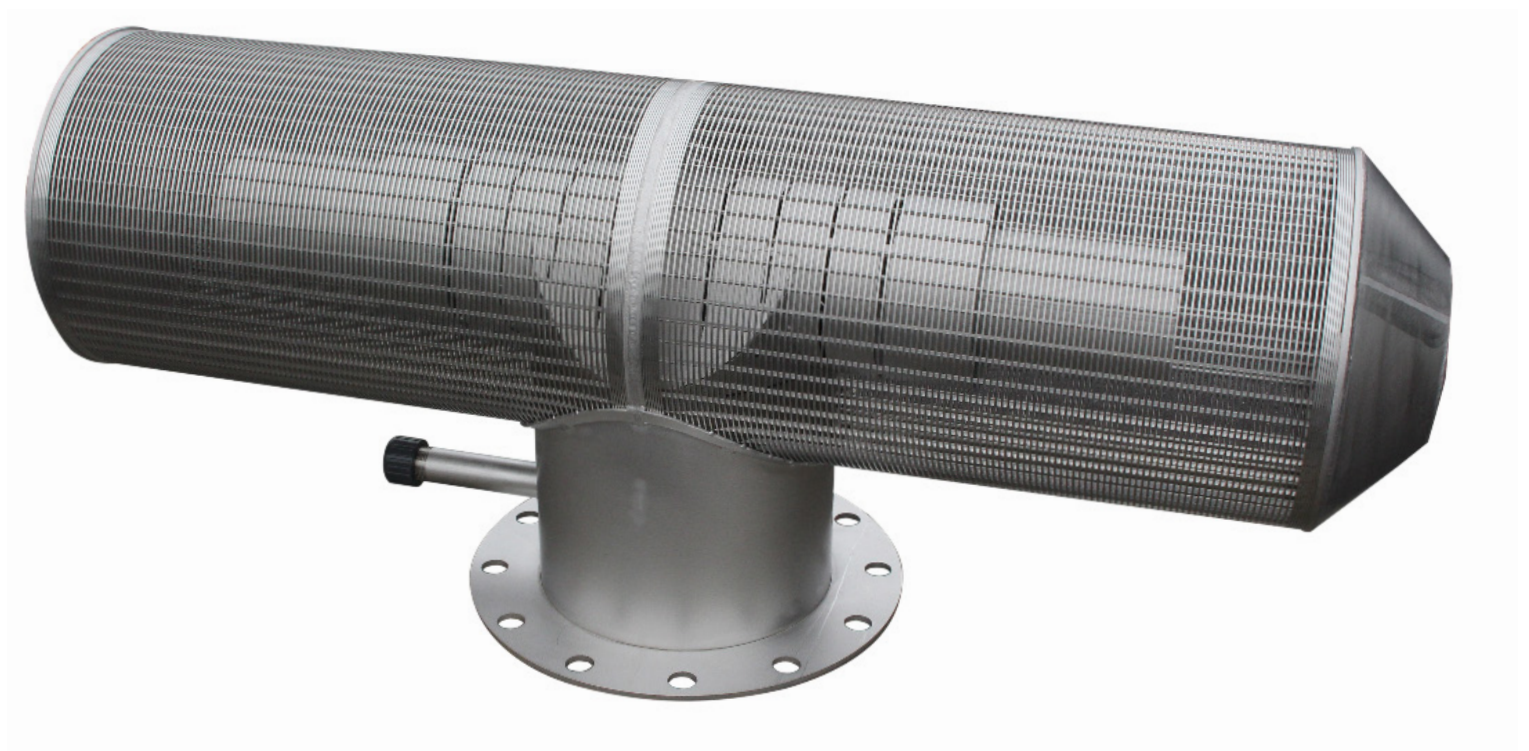

Dual pipe internal flow modifier

The key to success

Patented Internal Flow Modifier: Highest Efficiency and Lower Costs

The open pipe flow modifier is at the heart of the Johnson Screens passive intake screen system. This internal flow modifier development improves the design with a patented dual pipe flow modifier, and is now the industry standard.

The dual pipe flow modifier does two things: it produces an even flow across the entire screen surface, while not increasing the pressure drop. The low pressure drop across the screen surface reduces the amount of energy required to pull water through the screen, creating significant operating cost savings.

In Figure _01, the pressure drop difference between a restrictive pipe and an open pipe flow modifier illustrates the significant improvement of the Johnson Screens patented dual pipe internal flow modifier design. As more water is pumped through a restrictive pipe flow modifier, the pressure drop increases dramatically.

When the pressure drop increases on a passive intake screen, the pumping unit has to work much harder. Figure _02 shows a comparison between restrictive pipe and open pipe flow modifiers and the amount of energy required to pump water through a passive intake screen. The even flow and low pressure drop raise the overall efficiency of the screen to over 90%, allowing for smaller screen cylinders and Hydroburst components to be used.

Pressure Drop Comparison - Figure_01

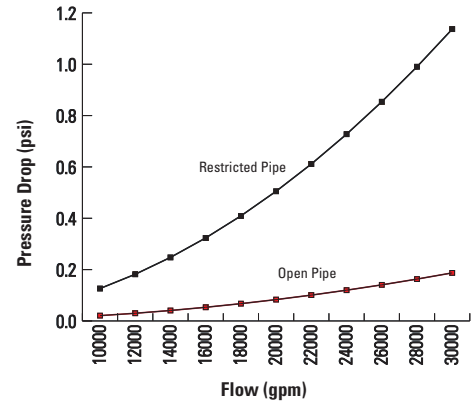

Electricity Demand Comparison - Figure_02

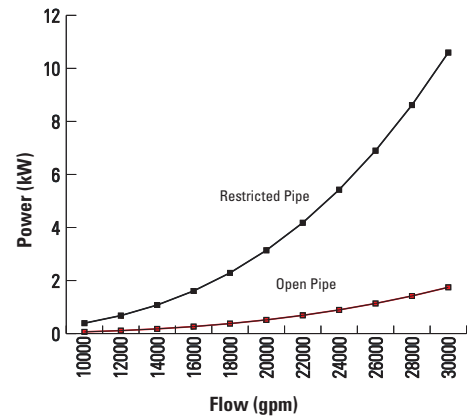

01 _ Computation Fluid Dynamic (CFD) Analysis shows the uniformity of the flow velocity across the entire passive intake screen surface area when using a dual pipe low modifier.

02 _ Max-Flow Intake. The Max-Flow passive intake design regulates entrance velocity across the screen face.

03 _ Max-Flow Intake. The Johnson Screens Max-Flow passive intake screens, have flow rates up to 40 percent greater than that of the previous models.

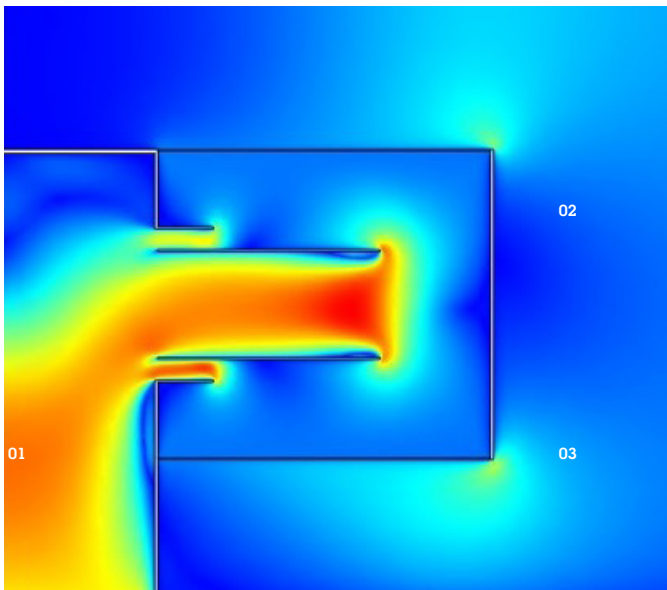

Vee-Wire Screen Design

- Controls the entrance velocity, or speed, of the water passing through the screen surface
- Has very high open area, allowing vast quantities of water to flow through
- Non-plugging design is easy to maintain
- Wide range of corrosion-resistant materials available
- Protects aquatic life from impingement.

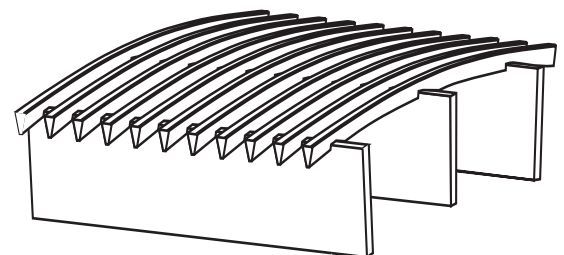

Johnson Screens Exclusive Max-Flow Intake System

Max-Flow, the Culmination of 60+ Years of Passive Intakes Expertise

Johnson Screens' next generation Passive Intake Screen, the Max-Flow™ design, increases flow capacity of the previous designs by up to 40% more.

The patent-pending design offers significant capital savings in any intake project by using smaller number of intake screens.

Additionally, a smaller Hydroburst System and significant less costs for the piping and civil work on a project will further increase project savings.

Max-Flow passive intake screens are available in all common Johnson Screens intake materials, including 304, 316, super duplex, and z-alloy.



New features include:

- 1.4 times more capacity than the previous design
- Newly redesigned internal modifier
- An efficient means to withdraw water by evenly distributing flow and reducing the velocity to a 0.5 feet per second or less
- Non-plugging design is easy to maintain using Johnson Screens patented Hydroburst screen cleaning system



Johnson Screens Passive Half Intakes for Shallow Water

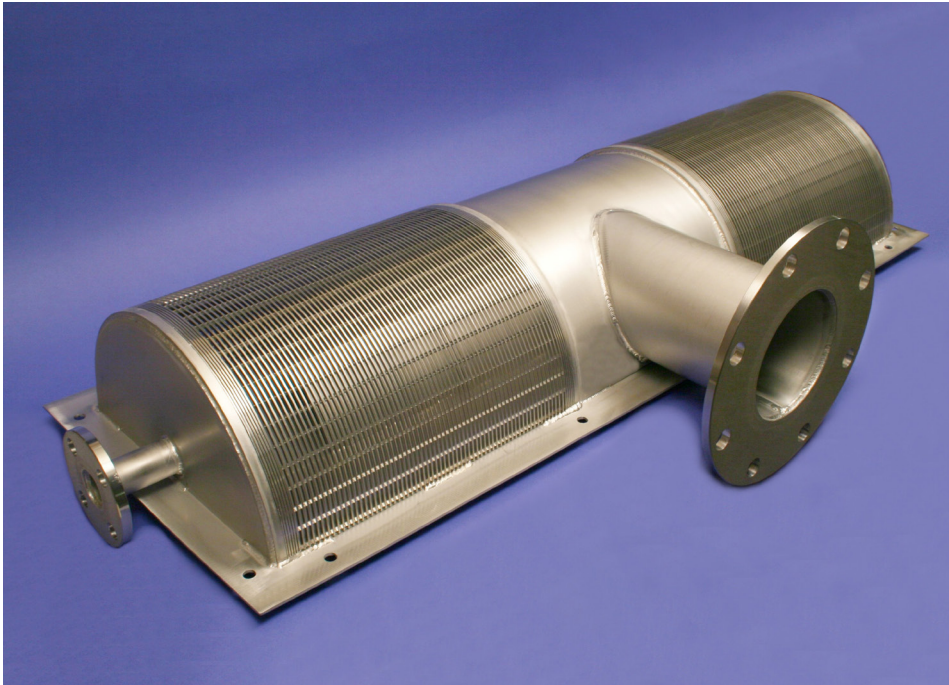

Based on the design of Johnson Screens' passive intake screen systems, the patent half screen intake system provides uninterrupted, environmentally safe water withdrawal from lakes, rivers and oceans. The half screen intake system allows for the screen to be used in half the operational depth of water of the traditional passive intake screen system.

Design features include:

- Low profile – half the water depth needed
- Hydroburst cleaning system option
- Passive intake screen – no maintenance
- Vee-Wire construction

As water demands expand for cities and towns, water resources previously harder to withdraw from, due to their shallow depth, now have become a more viable option.

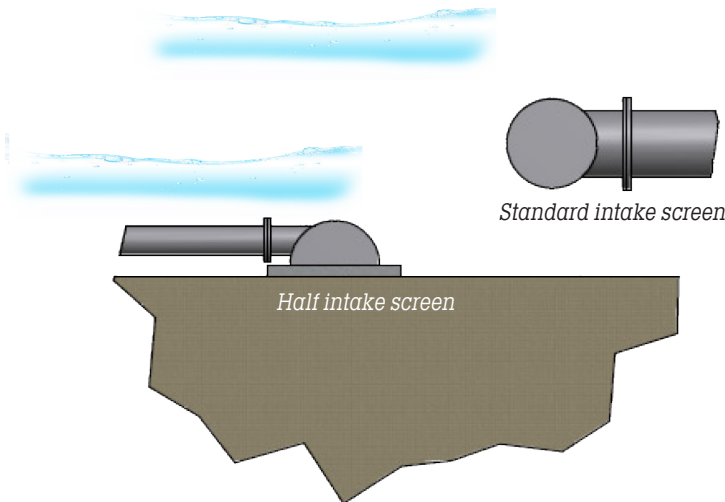

The half screen intake system is able to operate at half the water depth of traditional intake screen systems

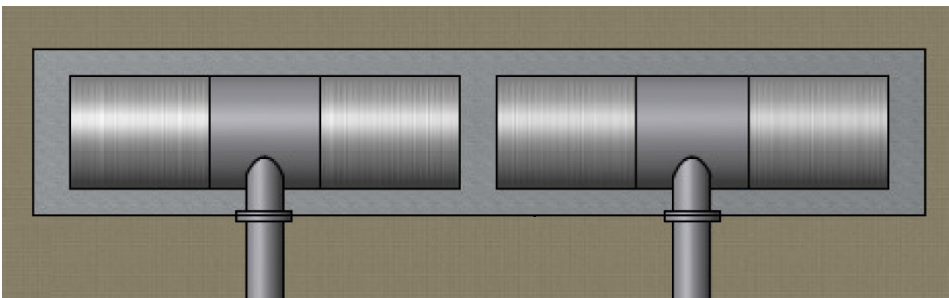

The half screen intake sits on a concrete pad and eliminates half the depth needed for the same flow

The general rule-of-thumb for proper intake screen depth has been to allow a half diameter of operational depth clearance from top and bottom, to prevent silt from being sucked up from the bottom and creating a vortex on the top of the water.

- Sits on a concrete pad and eliminates half the depth needed for the same flow
- Functions identically to the standard Johnson Screens passive intake screen system
- Uses the same control of flow distribution, with the patented multiple flow modifier design and Hydroburst system to keep the screen surface clean of debris
- Standard sizes range from 1/2T - 12HC to 1/2T - 96HC intake screens, and are typically applied in pairs

Typical Hydroburst air backwash cleaning system

Hydroburst Maximizes Intake System Efficiency

When debris in the water is high, the Hydroburst system provides fast and effective cleaning of the screen cylinders.

- Air volume is precisely matched to the intake screen cylinder size for maximum delivery
- Measured air burst forces debris away and scours the screen surface for highly effective cleaning
- Specially designed manifold distributes air inside the screen cylinder for optimal performance.

Varieties of controls are available, including manual, automatic activate on headloss and time activate.

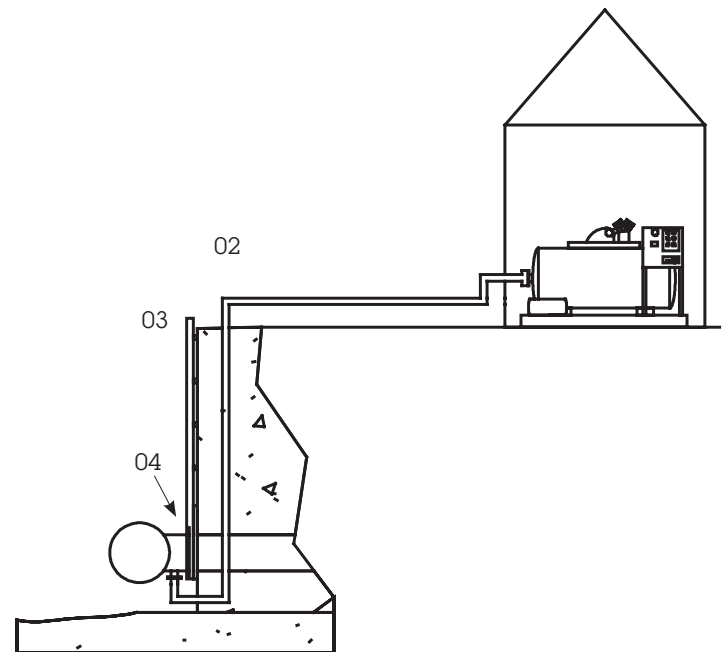
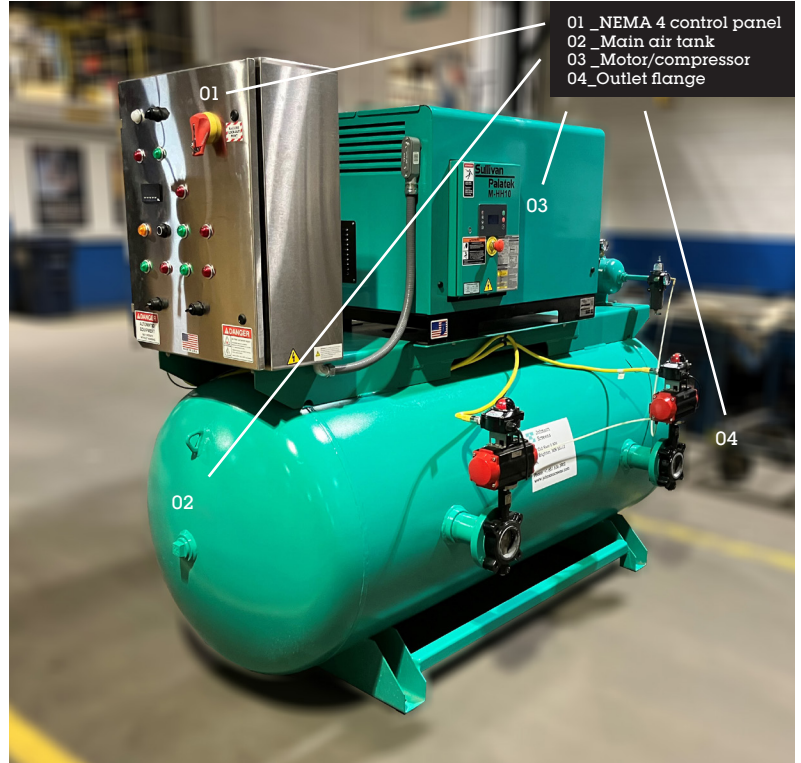

- 01_Hydroburst system cleaning
- 02_The Hydroburst is designed for a specific distance and depth of screen
- 03_Optional intake screen rail
- 04_ABW connection can also be on top of the screen

Passive intake screen systems

Optional designs, installation layout examples



Z-Alloy materials repel Zebra mussels, resists biofouling and minimizes corrosion in sea water

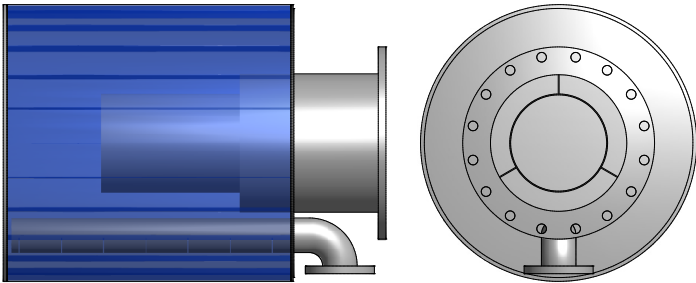
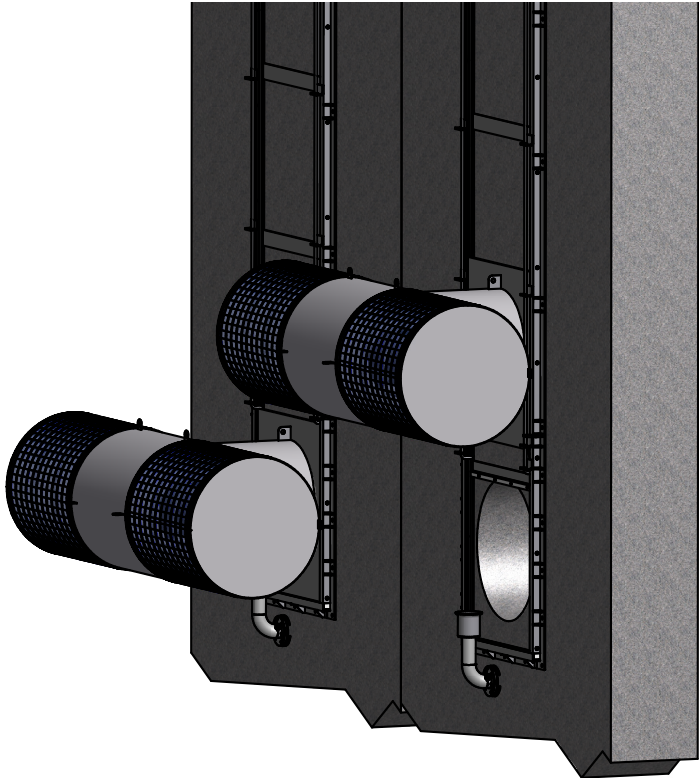

Single or Drum Intake Screen

Slide rails make raising and lowering of intake cylinders simple and easy

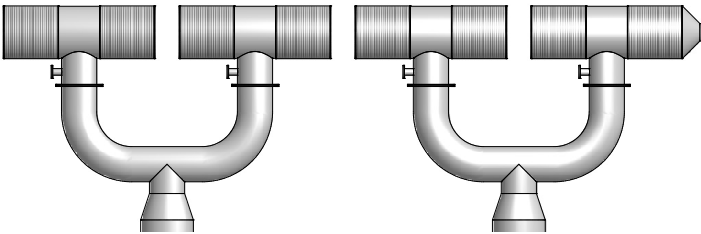

Multiple Screen Array Option

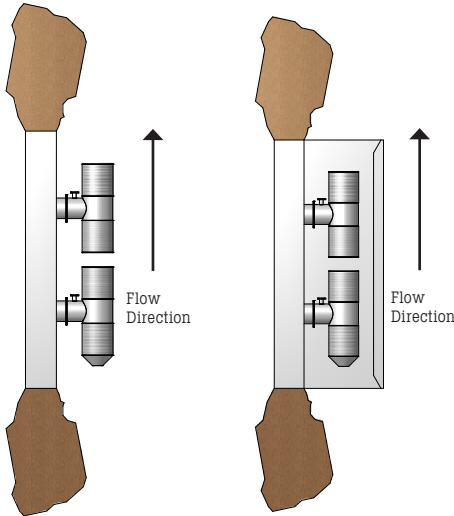

Typical Installation in faster moving, deeper rivers

Typical Installation in slower moving rivers with high sediment

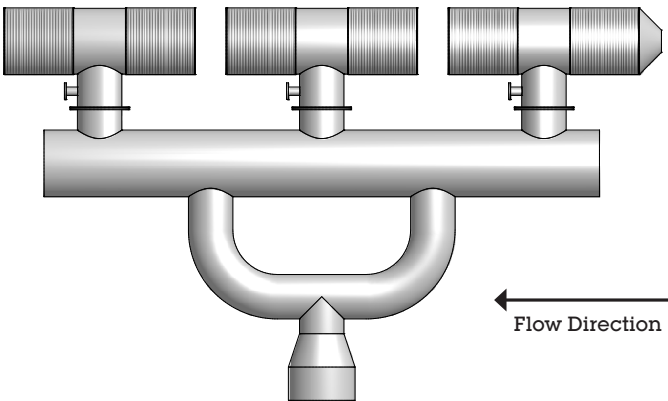

Manifold Installation Option

Johnson Screens
Industrial & Architectural Screens

North & South America
Phone +1 651 636 3900
info.us@johnsonscreens.com

Australia - Asia Pacific
Phone +61 7 3867 5555
info.au@johnsonscreens.com

Brazil
Phone +55 11 4341 5777
info.br@johnsonscreens.com

Chile
Phone +56 02 29280700
info.johnsonscreens.cl@johnsonscreens.cl

Europe
Phone +33 5 49021600
info.fr@johnsonscreens.com

India
Phone +91 2717 618000
info.in@johnsonscreens.com

Japan
Phone +81 45 661 3575
info.jp@johnsonscreens.com

johnsonscreens.com